

ELECTRA-STEER™



KIT NUMBER 8051490

John Deere Electric Steering Installation Manual

Thank you for purchasing our ELECTRA-STEER™ 12v electric assist power steering system. Please carefully read this instruction sheet entirely before you begin to install the system.

Remember before beginning installation, to insure that you are in a well lit, organized work area. Engage the parking brake, disconnect the battery until power is needed and chock or block the rear wheels to insure the vehicle is stable.

INSTALLATION TIPS:

Due to minor variations in vehicle frames, we recommend that you leave all the U-Joint pinch bolts loose until the motor is mounted. Then rock the steering wheel back and forth to allow the U-Joints to align themselves. Complete the installation by tightening these bolts.

KIT CONTENTS:

NOT PICTURED:

- (1) 544060 WIRING HARNESS
- (1) 620900 ELECTRICAL PACKET
- (1) 620890 HARDWARE PACKET

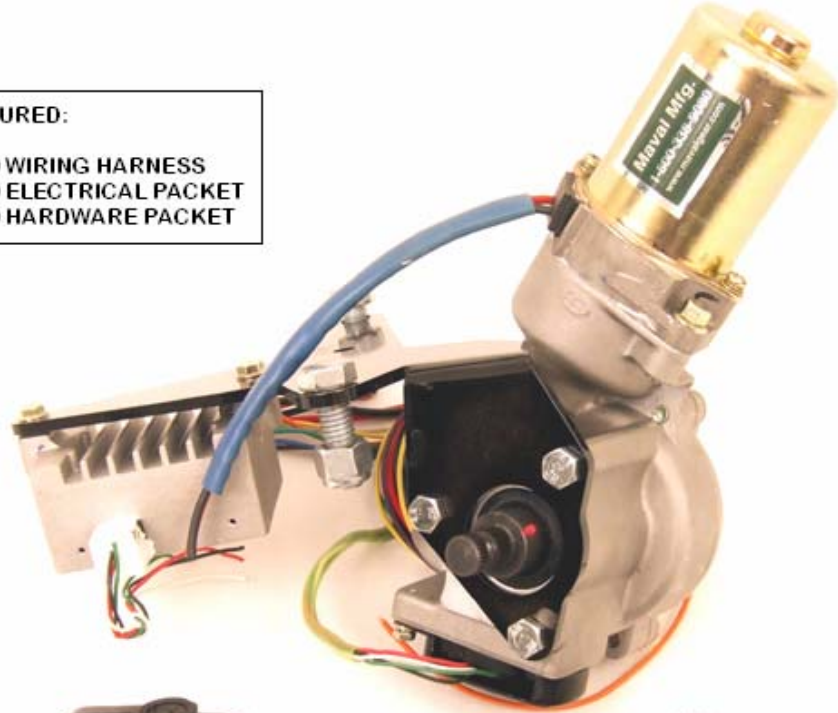

TOOLS NEEDED TO COMPLETE INSTALLATION:

- 3/8" Electric Drill
- 3/8" Drill Bit
- 1/2 " Drill Bit
- Soldering Iron & Solder
- Open End Wrenches: 10mm, 13mm & 17mm
- 3/8" Drive Socket Wrench and 6" extension
- Sockets: 15/16", 3/8", 8mm, 10mm, 13mm & 17mm
- Wire Stripper/Cutters
- Hammer
- 50 Ft Lb Adjustable Torque Wrench
- Scribe or Marking Tool
- Heat Gun

STEERING WHEEL AND SHAFT REMOVAL:

1. Open hood and remove plastic compartment from front of vehicle.



2. Remove center cap from steering wheel and remove 15/16 nut that holds wheel to the upper shaft. While pulling up on steering wheel have another person tap on the shaft to remove wheel.



3. Disconnect electrical connectors from back of dash and remove attaching hardware and remove dash assembly.



4. Remove lower allen bolt at rack and pinion that retains the shaft.



5. From the top, remove the snap ring on the upper groove and save it. Pull the shaft off of the rack and move it towards the electric fan so that the whole shaft can be dropped out of the column shroud and remove the entire shaft. You will not need this shaft any more.



6. Remove lower snap-ring from groove & slide down toward lower u-joint.



INSTALLATION OF THE ELECTRA-STEER™ KIT:

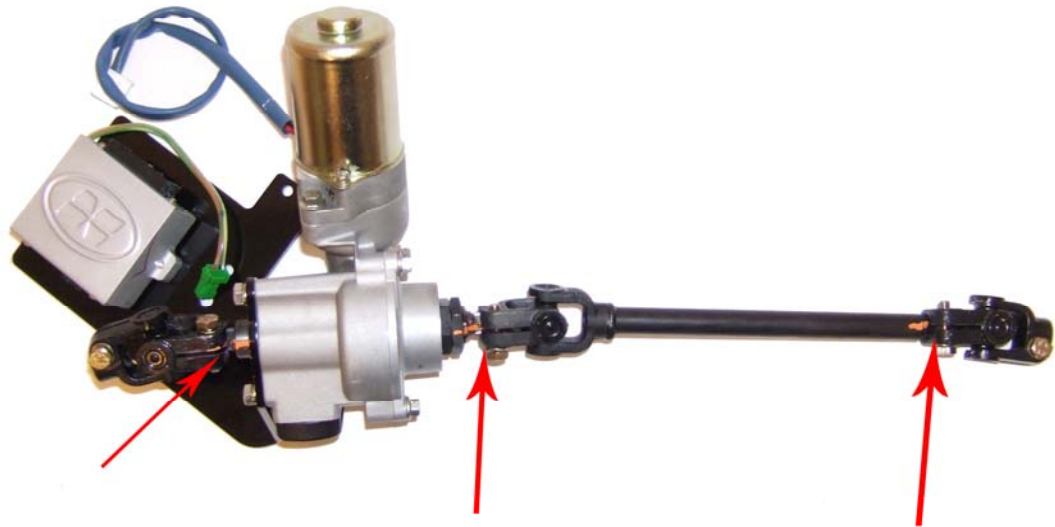

Note: The upper joint and lower shaft have been shipped attached and are in phase. The shaft, u-joint and motor are marked where the proper location is. You do not need to remove the upper joint, but you will need to remove the lower shaft for installation. Pay attention to the alignment marks and make sure you install them back into the same place.

1. Your electric motor and shafts and bracket have been shipped assembled. Pay attention to the marks on the motor and the shafts, you will need to remove the shaft's from the motor to install them need to be put back in the same spot that they came off of.

***FAILURE TO INSTALL THE SHAFTS IN THE PROPER LOCATION WILL CAUSE A "BUMP" OR UNEVEN STEERING EFFORT.**

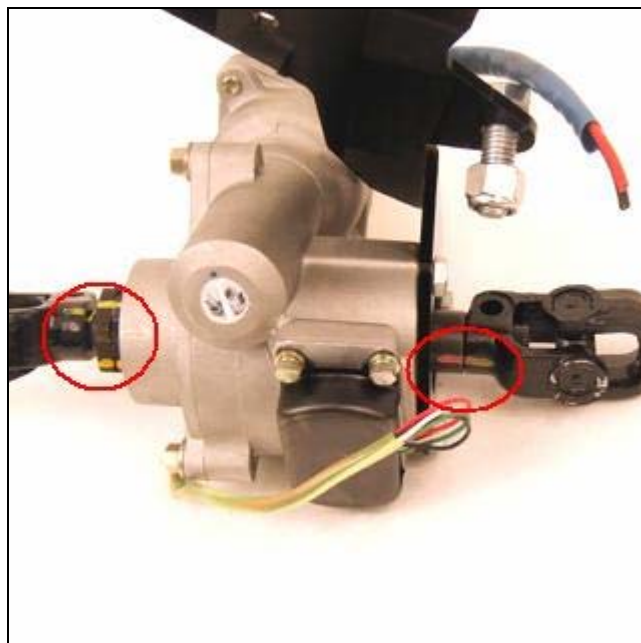

2. Remove the lower shaft from the motor. Install the lower shaft onto the rack assembly and slide bolt through and leave loose.

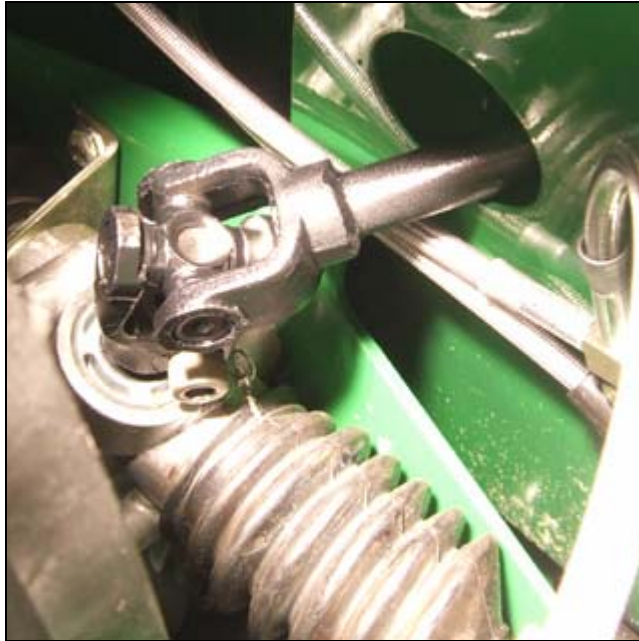

3. Install the lower snap ring from the stock shaft in the lower groove of the new upper shaft. Slide the upper shaft with motor attached through the column shroud. The motor bracket gets mounted to the two 1/2" holes on the left frame rail. While holding the motor in place with one hand, use the other to align the marks on the lower shaft and motor and spline the shaft and motor together. Install the 8mm bolt and leave loose.

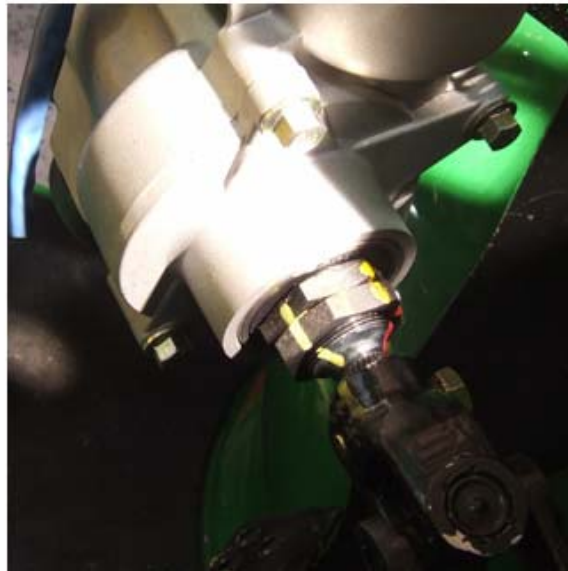
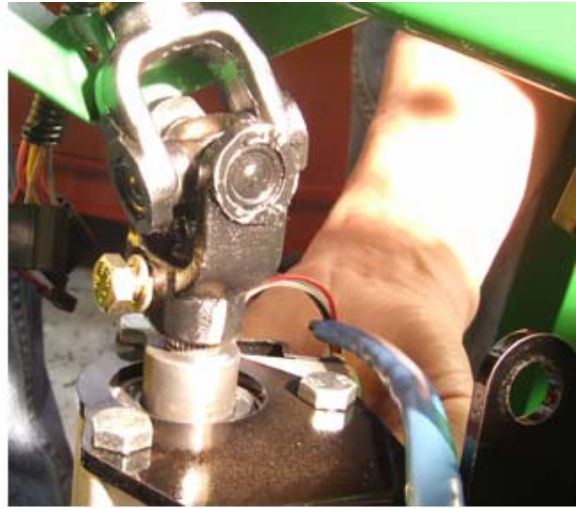
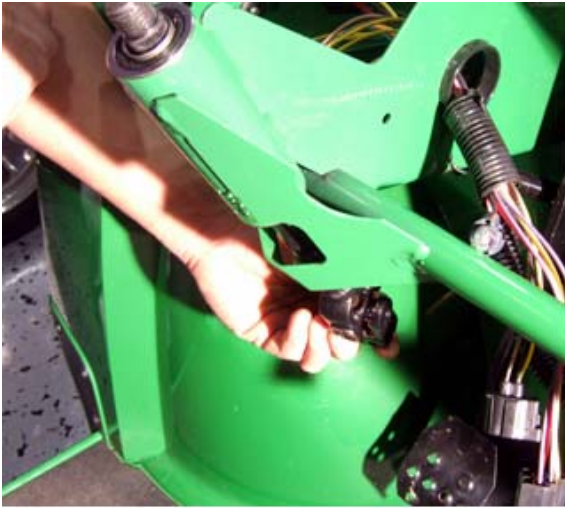

4. Rotate and align bolt-holes of bracket to holes on the frame. Install the 2- $\frac{1}{2}$ inch bolts supplied with kit through holes and install nuts and tighten into place.

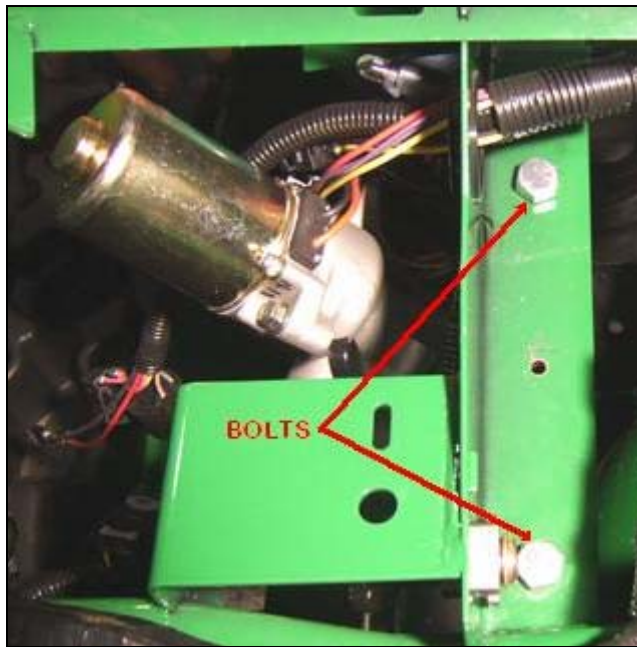

5. Next tighten the lower rack shaft bolt to 40 ft. lbs.
6. Tighten the remaining 8mm u-joint bolts to 25 ft. lbs.
7. The control module gets mounted to the bottom side of the mounting bracket. Install it and tighten the two attaching bolts to module.

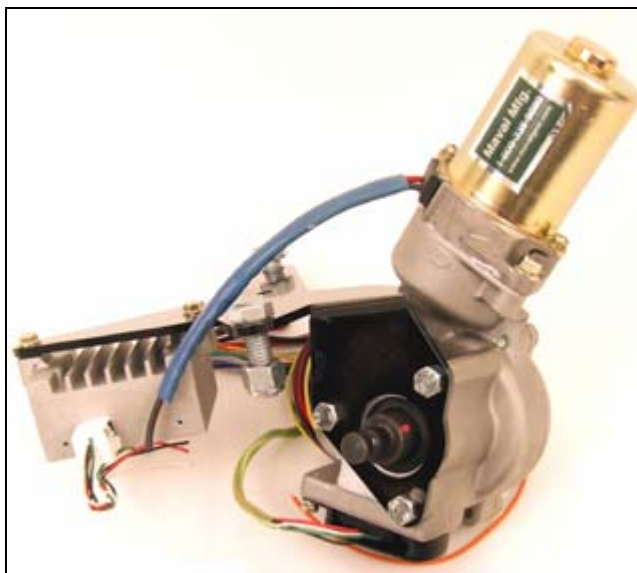

WIRING YOUR ELECTRA-STEER™ KIT:

1. The heavy red wire needs to go to a constant positive 12 volts. We normally go to the battery but any constant source will work.

Note: The 30 amp slow blow fuse needs to be installed in line with this wire to prevent damage or fire. ***Failure to do so may result in a short circuit or malfunction.**

2. The heavy black wire needs to go to a constant ground. Again we prefer the battery but a good and clean ground is fine.

****It is strongly suggested that all connections made be soldered & taped to insure integrity. Shrink tube is also supplied to seal your connections.***

3. The white wire gets a single spade connector put on it and is used for diagnostic purposes, so it need to stay in an accessible spot.
4. The purple wire gets a single spade connector put on it and is used for diagnostic purposes and also needs to stay in an accessible spot.

Note: *the White & Purple wires are used for trouble code reading and clearing. They need to be located in an accessible place. They do not get connected to anything.*

5. The orange wire goes to one of the sides of the LED light.
6. The yellow wire is not used for this application. It may be trimmed back and taped into the harness.
7. The green wire is connected to a key on power source usually we use the ignition switch lead. The other side of the LED also goes to this wire and may be spliced in anywhere in this wire.
8. Be sure to leave the orange wire and the green wire long enough to go through a hole in the dash where you want the light located.
9. Make sure your connections are good and your hardware is tightened to spec and there is no binding in your steering linkage.
10. Install the upper snap ring in upper shaft assembly. Install your dash and drill a ½ inch hole where you want the LED to be. Run your orange and green wires through the hole and wire in your light. After your connection is made simply push the LED into the hole until it snaps in place.
11. Install your steering wheel and torque to 35 ft. lbs. Make sure your wheels are straight and that you install your steering wheel straight.
12. When you are done, you can turn the ignition key to the on position. The LED will light for about 5 seconds. This is a normal function. When the light goes out your steering should work. Verify that nothing is binding and there is no trouble light. Each time the key is cycled the LED will light for the 5 seconds this is a prove out, and is normal.

The ELECTRA-STEER™ unit is designed to “shut down” if it becomes overheated reverting the vehicles manual steering capabilities.

If the unit ceases operation after extensive use or in an extreme environment it will automatically resume it’s normal function once it has cooled.

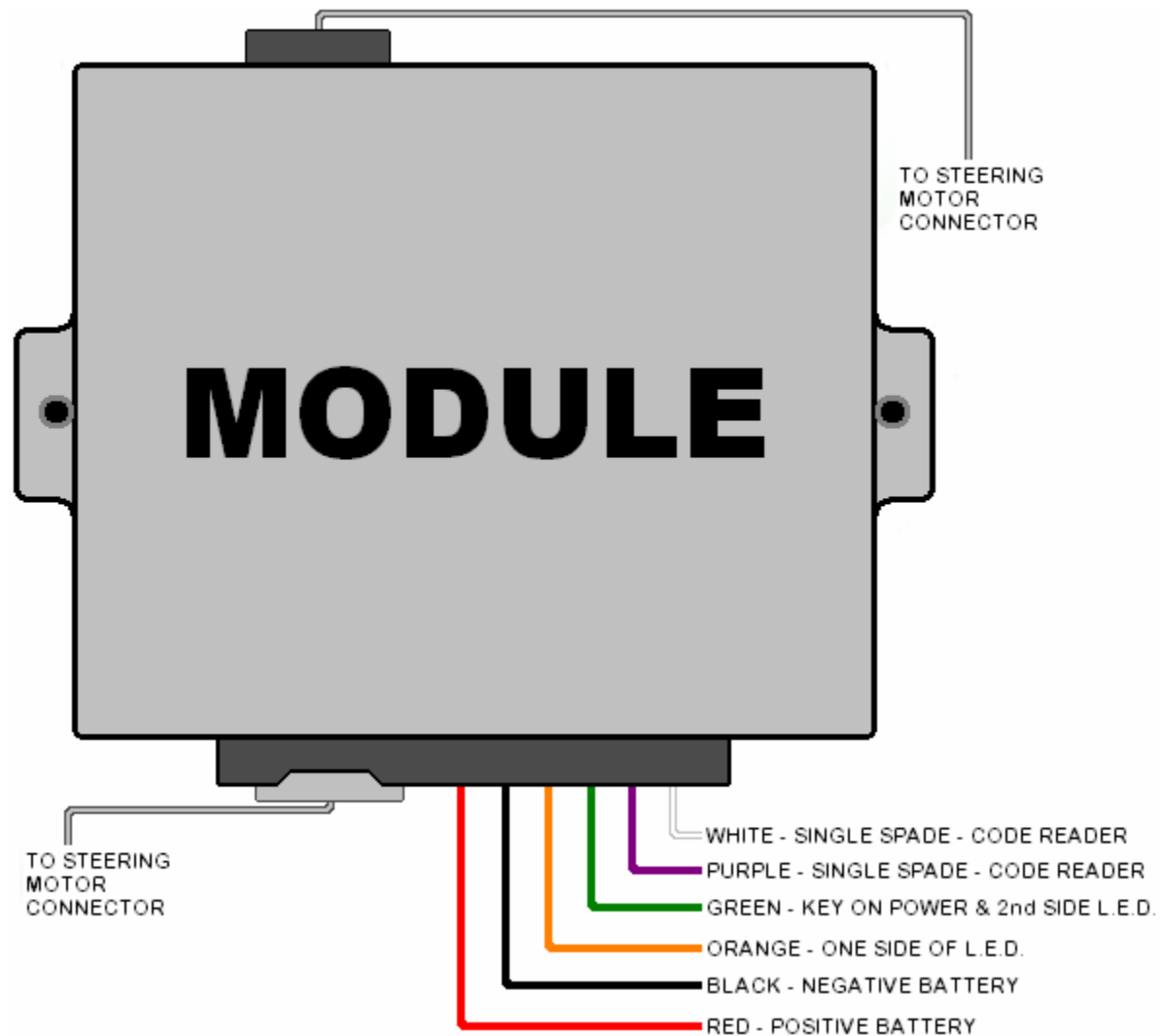

The Electra-Steer™ Power Steering Assist Unit is intended to be used in accordance with all safety recommendations of the original manufacturer of the vehicle as specified in the Owners Manual. This product is intended for normal operation of the vehicle as specified by the original manufacturer. Maval Manufacturing Inc. and Unisteer Performance Products recommend that this product should not be used in extreme environmental conditions or in competitive activities. Maval Manufacturing Inc. and Unisteer Performance Products do not accept liability for any malfunction, damage, or injury incurred as a result of use of this product in extreme environmental conditions or in competitive activities.

Electra Steer Diagnosis Trouble Code Reading and Code Clearing

1. Verify that your trouble code light is on steady.
2. Peel back a small portion of the orange trouble code light wire to expose the copper portion of it.
3. Next use a jumper wire and go from the purple wire with the single spade connector on it and touch or spike it to the exposed part of the orange wire. You may need to do this a couple of times to get the LED to blink or flicker. Once you see the LED flicker or blink stop spiking the purple to orange and wait for LED to start blinking a code.

4. The light will flash in a sequence like 1 and then 123. This code flash would be interpreted as a code 13. The code will repeat itself 3 times and then go to the next code if there is one in the system. You need to wait till all the codes are read and recorded.
5. Once you know what the codes are you can use this chart to tell where or what the problem may be.
6. Once you have determined what the problem is and make the necessary repairs, you can proceed to clear the codes by running a jumper wire from the white wire with the single spade connector on it to ground.
7. Verify the ignition is off. Place the white wire to ground. Turn key on, wait 5 seconds and the light should go out. When the light goes out turn off ignition and remove jumper wire. Once all repairs are made turn ignition on and see that light proves out normally. This is all there is to it.

Trouble Code	Problem	Diagnosis
41-42-43-44-45-51	Electric motor Malfunction	Change Electric Motor
11-13-14-15	Torque Sensor	Change Sensor
52-54-55	ECU Malfunction	Change Computer
22	No Engine Input	Computer Error
21-23-24	No Speed Signal	Computer Error

We welcome your suggestions & comments to make this or any of our installations better! If you have any questions or problems regarding this product please contact us at:

**1555 Enterprise Parkway
Twinsburg OH 44087
800-338-9080**

WWW.UNISTEER.COM

655730
(01/03/08)